

# SPS 沉水式污水泵

SUBMERSIBLE SEWAGE PUMP



泵浦 曝氣系統 廢水處理機械

TAF水泵實驗室認證合格廠  
品質管理系統ISO 9001



綠色 · 安全 · 永續經營

## 川源股份有限公司

GSD INDUSTRIAL CO., LTD.

## 特點 FEATURES

- ▶ **構造：**  
專為汙水排送而設計的沉水泵
- ▶ **馬達保護裝置：**  
可依需要加裝溫度保護器
- ▶ **完全防水：**  
採用優良廠牌機械軸封，並配合高級潤滑，保證不漏水、不損軸心，可免除故障之虞。
- ▶ **馬達等級：**鼠籠式感應電動機，絕緣等級均為F級並符合IP68。

- ▶ **SPECIAL DESIGN:**  
Submersible designed to work in waste water.
- ▶ **MOTOR PROTECTION DEVICE:**  
Build-in thermalstat be automatically IP68 design, qualified mechanical seal and bearings.
- ▶ **Motor:**  
Squirrel cage installation motor, F class insulation and accordance with IP68.

## 用途 APPLICATIONS

- ▶ 土木建築工程施工
  - ▶ 大樓地下排水汙水設備
  - ▶ 工廠廢水設備
  - ▶ 下水道排水工程
  - ▶ 農業灌溉及養魚、噴水專用
  - ▶ 船舶排水及其他積水、排水專用
- ▶ Construction engineering
  - ▶ Basement Drainage
  - ▶ Wastewater treatment
  - ▶ Drainage system
  - ▶ Agricultural irrtrion, fishing and spraying.
  - ▶ Water discharge work for ships, any kind of accumulated water and water discharge.

## 型號說明 PRODUCT NUMBER DESCRIPTION

**S - 6 7.5 - 100 - S**

				單相：S	SINGLE PHASE：S		
				出口口徑	OUTLET DAIMETER(mm)		
				額定動力	RATED POWER(kW)		
				頻率	FREQUENCY(Hz) 5：50；6：60		
				標準形式SPS	PUMP TYPE		

本機型可搭配沉水耐壓防爆馬達使用，因防爆馬達須符合法規並依客戶需求生產，請聯繫我司窗口索取相關資料。

SPS series products can be assembled with submersible explosion-proof motors, wich are designed by laws and regulations, on request.

Please contact us to obtain relative information.



## 性能曲線圖 PERFORMANCE CURVE

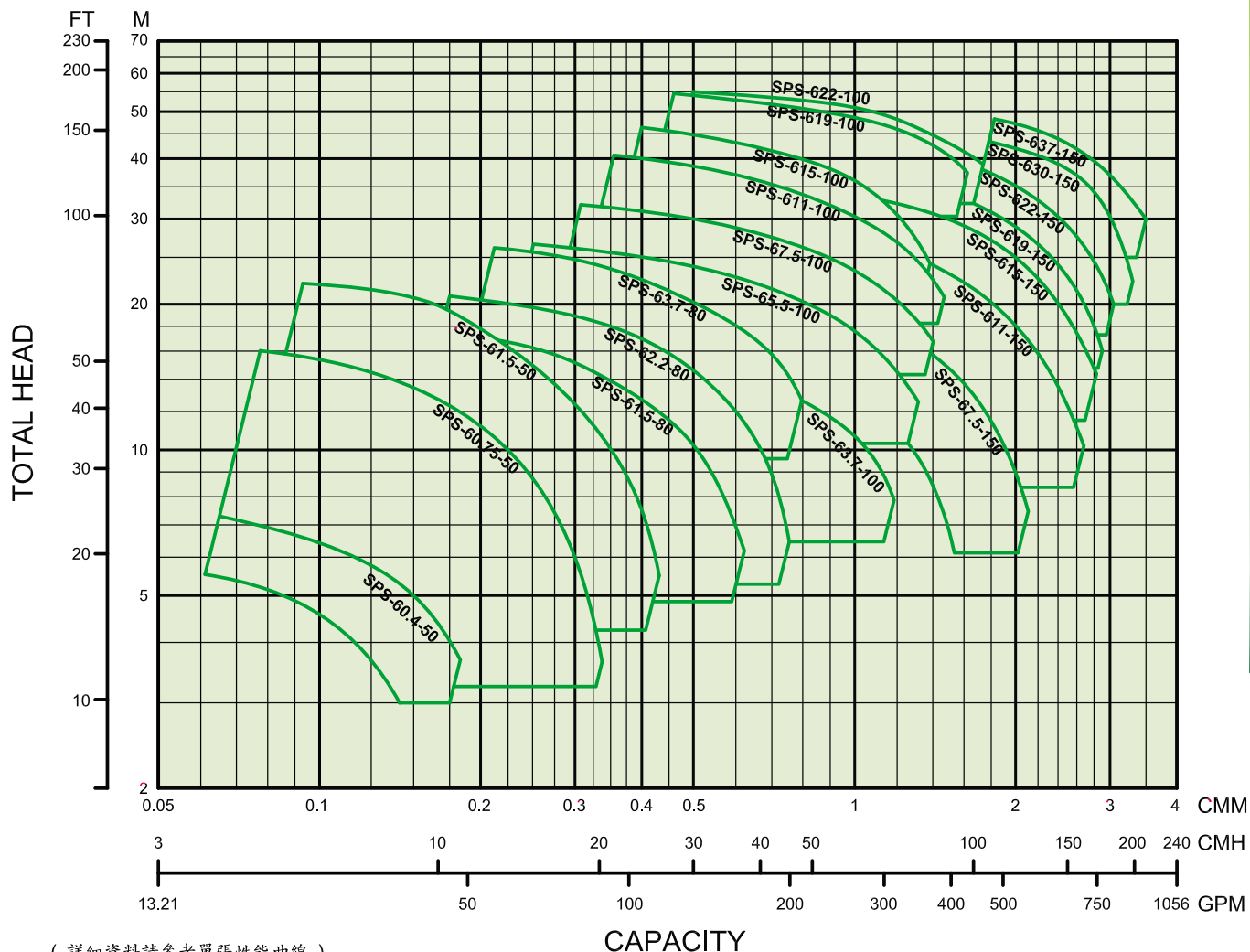

( 詳細資料請參考單張性能曲線 )

● Detail information, please refer to the specific performance curve sheet

## 標準規格表 SPECIFICATIONS

機 型 TYPE	頻率/極數 Hz/Pole	出口口徑	出力	揚程	流量	略重
		Disch. Dia mm	Output HP/KW	Head M	Capacity CMM	Weight Kg
S-60.4-50-S	60/2	50	0.5/0.4	5	0.15	17.5
S-60.4-50	60/2	50	0.5/0.4	5	0.15	17.5
S-60.75-50-S	60/2	50	1/0.75	10	0.2	21
S-60.75-50	60/2	50	1/0.75	10	0.2	21
S-61.5-50	60/2	50	2/1.5	14	0.24	23.5
S-61.5-80	60/2	80	2/1.5	14	0.33	28.5
S-62.2-80	60/2	80	3/2.2	15	0.41	33
S-63.7-80	60/2	80	5/3.7	20	0.5	36
S-63.7-100	60/2	100	5/3.7	12	0.8	70
S-65.5-100	60/2	100	7.5/5.5	17.5	1.0	75
S-67.5-100	60/2	100	10/7.5	23	1.0	80
S-611-100	60/2	100	15/11	30	1.0	85
S-615-100	60/2	100	20/15	36	1.0	90
S-619-100	60/2	100	25/18.5	42	1.2	98
S-622-100	60/2	100	30/22	50	1.2	112
S-67.5-150	60/2	150	10/7.5	13	1.5	105
S-611-150	60/2	150	15/11	22	1.5	120
S-615-150	60/2	150	20/15	25	1.8	160
S-619-150	60/2	150	25/18.5	31	1.8	172
S-622-150	60/2	150	30/22	37	1.8	183
S-630-150	60/2	150	40/30	36	2.5	194
S-637-150	60/2	150	50/37	41	2.5	202

# 標準結構圖 CONSTRUCTION

標準型 (standard)

<0.5~2HP 2" >

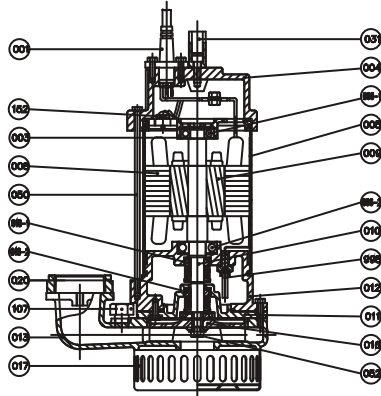

著脫型 (with aout-discharge connector)

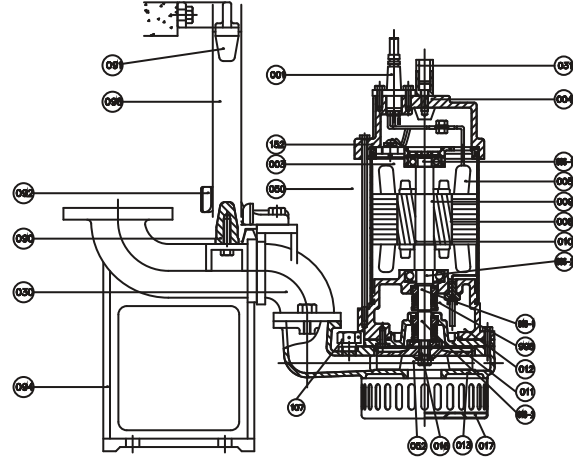

<2~15HP >

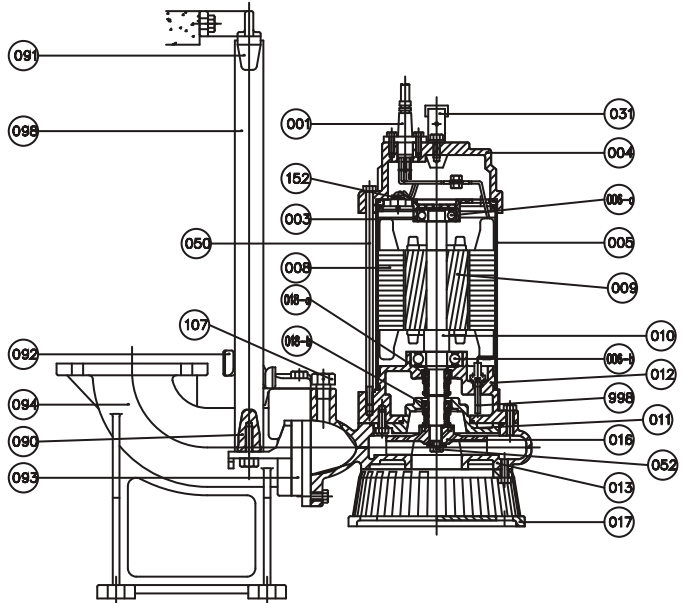
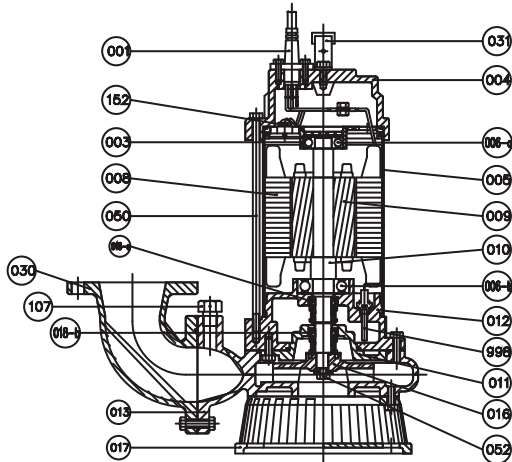

<20HP以上 >

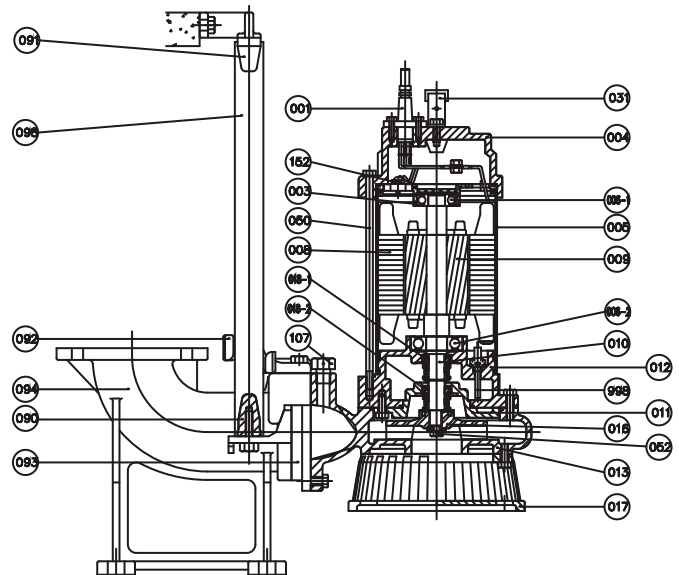
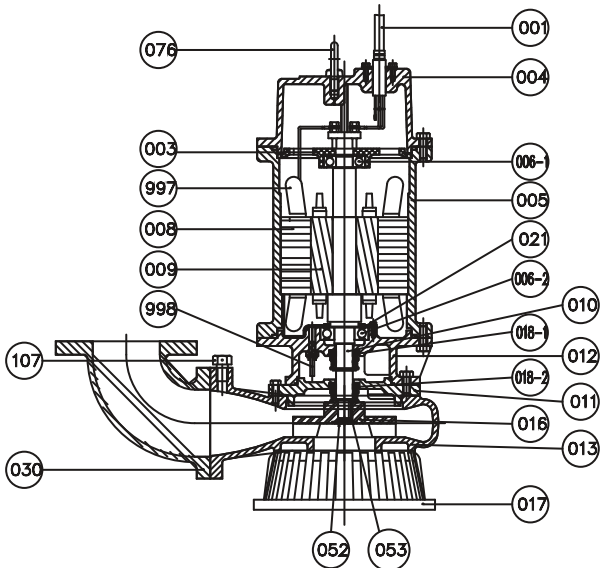

## 標準材質圖 MATERIALS

No	名稱	NAME	材質(MATERIAL)			備註
			A	B	C	
001	電 纜	Cable	VCT(or 2CT)	VCT(or 2CT)	VCT(or 2CT)	
003	軸 承 座	Bearing Cover	FC200	SCS13	SCS14	
004	馬 達 蓋	Motor Cover	FC200	FC200	FC200	
005	馬達本體	Motor Casing	SUS304	SUS304	SUS316	15HP(含)以下 0.5HP~15HP 20HP(含)以上 20HP~
			FC200	SCS13	SCS14	
006a	軸 承	Bearing	-----	-----	-----	
006b	軸 承	Bearing	-----	-----	-----	
008	定 子	Stator	F CLASS	F CLASS	F CLASS	
009	轉 子	Rotor	-----	-----	-----	
010	主 軸	Shaft	SUS410	SUS304	SUS316	
011	油 箱 蓋	Oil Cover	FRPP	FRPP	FRPP	2HP(含)-50mm口徑以下 2HP & Below 50mm outlet
			FC200	SCS13	SCS14	
012	中 承 座	Bracket	FC200	SCS13	SCS14	
013	泵 浦 本 體	Pump Casing	FC200	SCS13	SCS14	
016	葉 輪	Impeller	FRPP	SCS13	SCS14	5HP(含)-80mm口徑以下 5HP & Below 80mm outlet
			FC200	SCS13	SCS14	
			SS400	SS400	SS400	
017	濾 底 座	Strainer Stand	FC200	SCS13	SCS14	
018a	機 械 軸 封	Mechanical Seal	CARBON-NBR	CARBON-NBR	CARBON-NBR	
018b	機 械 軸 封	Mechanical Seal	Silicon-NBR	Silicon-NBR	Silicon-Viton	
030	彎 頭	discharge Band	FC200	SCS13	SCS14	
031	把 手	Handie	工程塑膠	工程塑膠	工程塑膠	50mm(含)口徑以下 Below 50mm outlet
			SUS304	SUS304	SUS316	
032	防 潮 裝 置	Space Heater	-----	-----	-----	選擇配備Optional accessories
050	螺 桿	Bolt	SUS304	SUS304	SUS316	
052	葉 輪 螺 絲	Impeller Nut	SUS304	SUS304	SUS316	
076	環 首 螺 絲	Eye Bolt	SS400 ; SUS304			
090	固 定 柱	Bolt	FC200	FC200	FC200	
091	固 定 架	Guide Holder	FC200	FC200	FC200	
092	引 導 板	Slide	FC200	SCS13	SCS14	
093	配 合 凸 緣	Flange Setter	FC200	SCS13	SCS14	
094	著 脫 本 體	Discharge Connection	FC200	SCS13	SCS14	
107	排 氣 閥	Vent Valve	FRPP	FRPP	FRPP	
152	過 熱 保 護 器	Thermalstat	-----	-----	-----	5HP(含)以下 · 為標準配備 0.5~5HP standard accessories
997	溫 度 保 護 器	Motor Protector	-----	-----	-----	選擇配備Optional accessories
998	測 漏 檢 知 器	Leakage Detector	-----	-----	-----	選擇配備Optional accessories

- 註： 1 · 032、152、997、998為選擇配備。032、152、997、998 are optional accessories.  
2 · 上述材質以外，可依客戶需求製作。In addition to the above materials, it can be made according to customer needs.  
3 · 5HP(含)以下規格不銹鋼材質，請選用本公司SSP產品。Please use our SSP products for stainless steel with specifications of 0.5~5HP.  
4 · 15HP(含)以下馬達本體採用SUS不銹鋼沖壓外殼。The motor casing below 15HP (inclusive) adopts SUS stainless steel stamping shell.

## 標準型外型尺寸表 STANDARD TYPE DIMENSIONS

機型Type	圖 FIG.	A	B	C	D	E	F	G	H
S-60.4-50S	A	135	330	399	181	-	89	229	269
S-60.4-50		135	330	399	181	-	89	229	269
S-60.75-50S		135	390	459	181	-	89	229	269
S-60.75-50		135	350	419	181	-	89	229	269
S-61.5-50		135	398	467	181	-	89	229	269
S-61.5-80	B	204	405	482	231	114	150	264	421
S-62.2-80		204	465	542	231	114	150	264	421
S-63.7-80		204	465	542	231	114	150	264	421
S-63.7-100		251	479	556	289	140	200	264	572
S-65.5-100		251	480	693	288	140	200	467	572
S-67.5-100		251	500	693	288	140	200	467	572
S-611-100		257	540	709	295	143.5	220	490.5	595
S-615-100	C	256.5	650	829	309	150	220	495	600
S-619-100		256.5	650	829	309	150	220	495	600
S-622-100		256.5	650	829	309	150	220	495	600
S-65.5-150	B	307	495	709	344	169	220	551	691
S-67.5-150		307	515	709	344	169	220	551	691
S-611-150		307	540	709	344	169	220	551	691
S-615-150	C	307	650	829	337	169	220	551	691
S-619-150		307	650	829	337	169	220	551	691
S-622-150		307	650	829	337	169	220	551	691
S-630-150		374	810	1160	370	185	240	585	725
S-637-150		374	845	1126	370	185	240	585	725

# 標準型外型尺寸圖 STANDARD TYPE DIMENSIONS

標準型 (standard)

<0.5~2HP 2"><Fig.A>

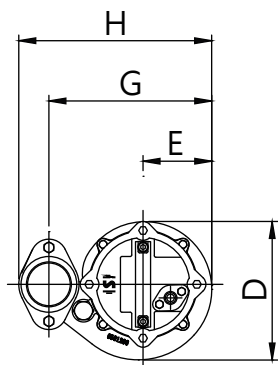

<2~15HP><Fig.B>

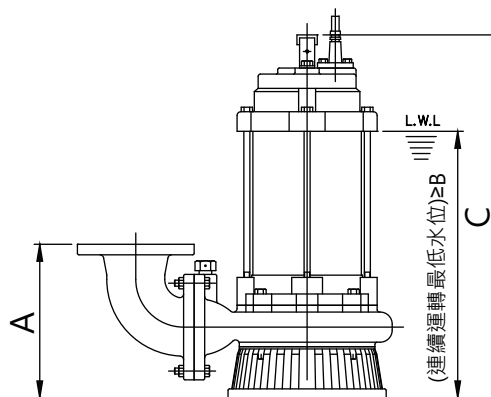
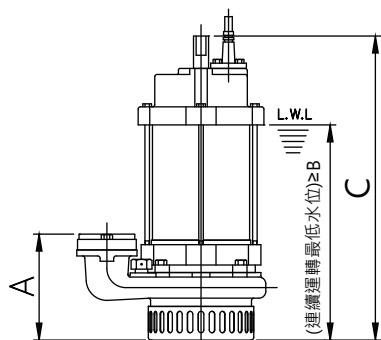
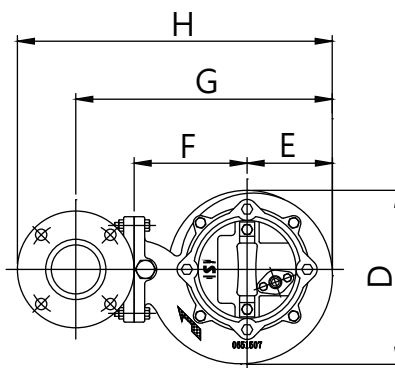

<20HP以上> <Fig.C>

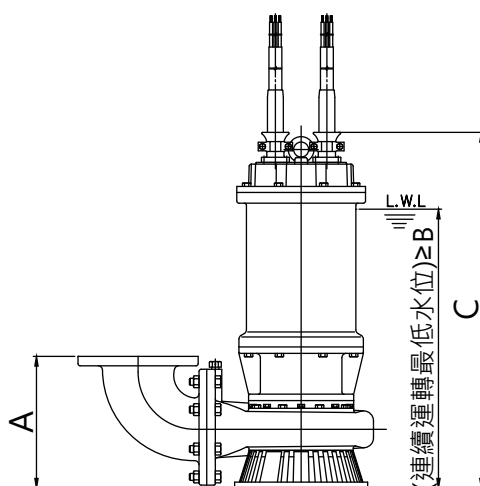
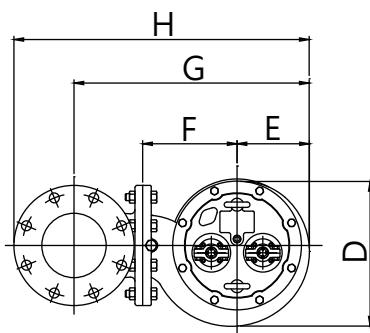

# 著脫型外型尺寸表 AUTO-DISCHARGE TYPE DIMENSIONS

機型 Type	圖 FIG.	A	B	C	D	E	F	G	H	I	J	K	L	M	N	O	P	Q	R	S	T
S-60.4-50S	D	310	390	459	184	91.5	221	130	507	120	150	110	180	60	25A	59	240	140	15	M12	2.5
S-60.4-50		310	390	459	184	91.5	221	130	507	120	150	110	180	60	25A	59	240	140	15	M12	2.5
S-60.75-50S		310	390	459	184	91.5	221	130	507	120	150	110	180	60	25A	59	240	140	15	M12	2.5
S-60.75-50		310	390	459	184	91.5	221	130	507	120	150	110	180	60	25A	59	240	140	15	M12	2.5
S-61.5-50		310	458	527	184	91.5	221	130	507	120	150	110	180	60	25A	59	240	140	15	M12	2.5
S-61.5-80	E	280	490	568	231	114	224	140	554	180	200	180	225	86	25A	59	240	140	15	M16	21.5
S-62.2-80		280	510	568	231	114	224	140	554	180	200	180	225	86	25A	59	240	140	15	M16	21.5
S-63.7-80		280	550	628	231	114	224	140	554	180	200	180	225	86	25A	59	240	140	15	M16	21.5
S-63.7-100		340	550	627	289	140	308	156	709	180	220	180	240	71	40A	65	345	295	25	M16	54
S-65.5-100		340	570	748	289	140	308	156	709	180	220	180	240	71	40A	65	345	295	25	M16	54
S-67.5-100		340	570	748	289	140	308	156	709	180	220	180	240	71	40A	65	345	295	25	M16	54
S-611-100		340	605	758	289	143	328	156	732	180	220	180	240	65.5	40A	65	345	295	25	M16	54
S-615-100		F	340	715	885	309	150	328	156	739	180	220	180	240	65.5	40A	65	345	295	25	M16
S-619-100	340		715	895	350	150	328	156	739	180	220	180	240	54	40A	65	345	295	25	M16	54
S-622-100	339		750	937	315	156	319	156	736	180	220	180	240	65.5	40A	65	345	295	25	M16	54
S-65.5-150	E	445	640	857	343	169	367	225	901	225	250	240	380	148	50A	100	470	400	25	M20	22
S-67.5-150		445	660	857	343	169	367	225	901	225	250	240	380	148	50A	100	470	400	25	M20	22
S-611-150		445	785	1021	343	169	367	225	901	225	250	240	380	148	50A	100	470	400	25	M20	22
S-615-150	F	445	785	1021	337	169	367	225	901	225	250	240	380	148	50A	100	470	400	25	M20	22
S-619-150		445	785	1021	337	169	367	225	901	225	250	240	380	148	50A	100	470	400	25	M20	22
S-622-150		445	785	1021	337	169	367	225	901	225	250	240	380	148	50A	100	470	400	25	M20	22
S-630-150		445	954	1340	370	185	367	225	937	225	250	240	380	81	50A	100	470	400	25	M20	22
S-637-150		445	925	1207	370	185	386	225	936	225	250	240	380	81	50A	100	470	400	25	M20	22

著脫型(with auto-discharge connector) <Fig.D>

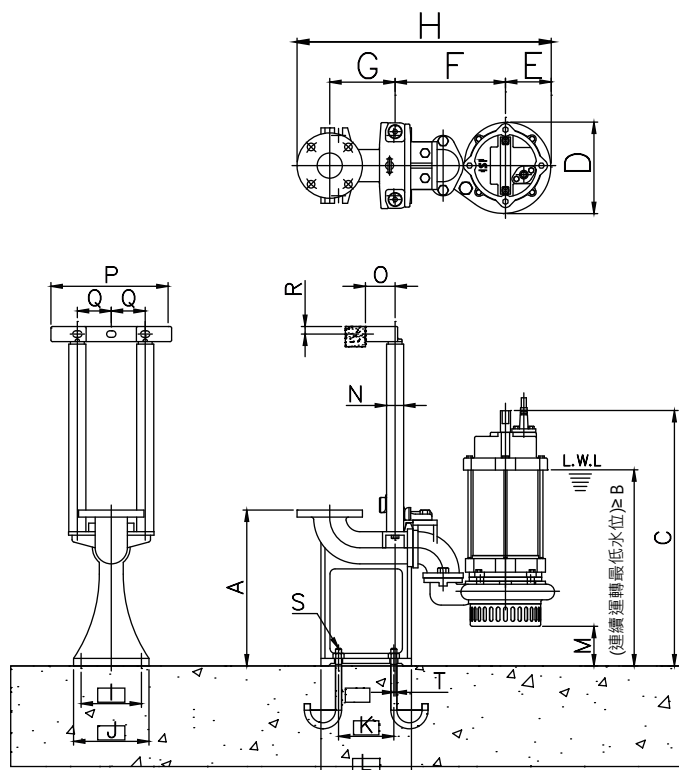

# 著脱型外型尺寸表 AUTO-DISCHARGE TYPE DIMENSIONS

<2~15HP> <Fig.E>

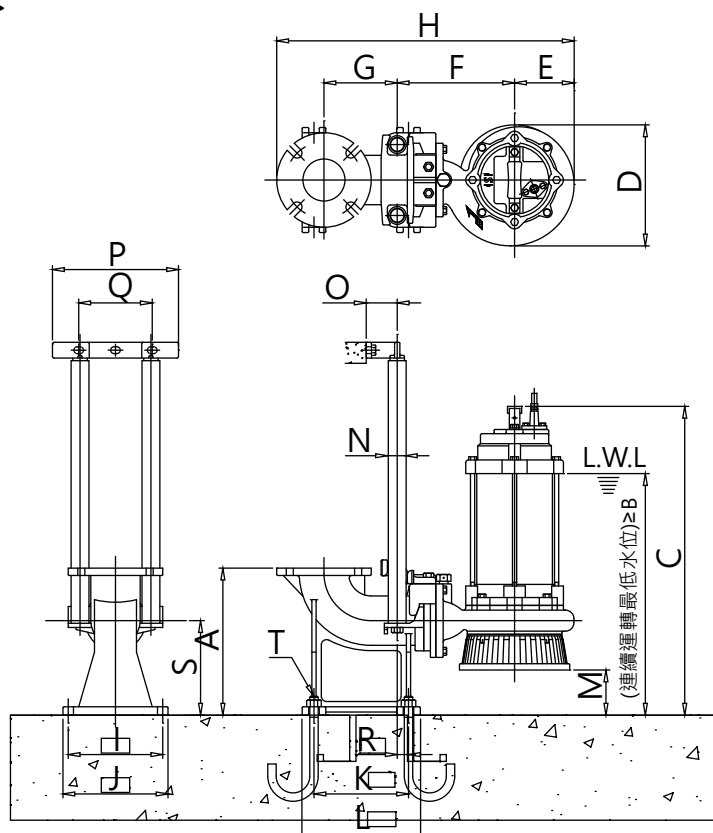

<20HP以上> <Fig.F>

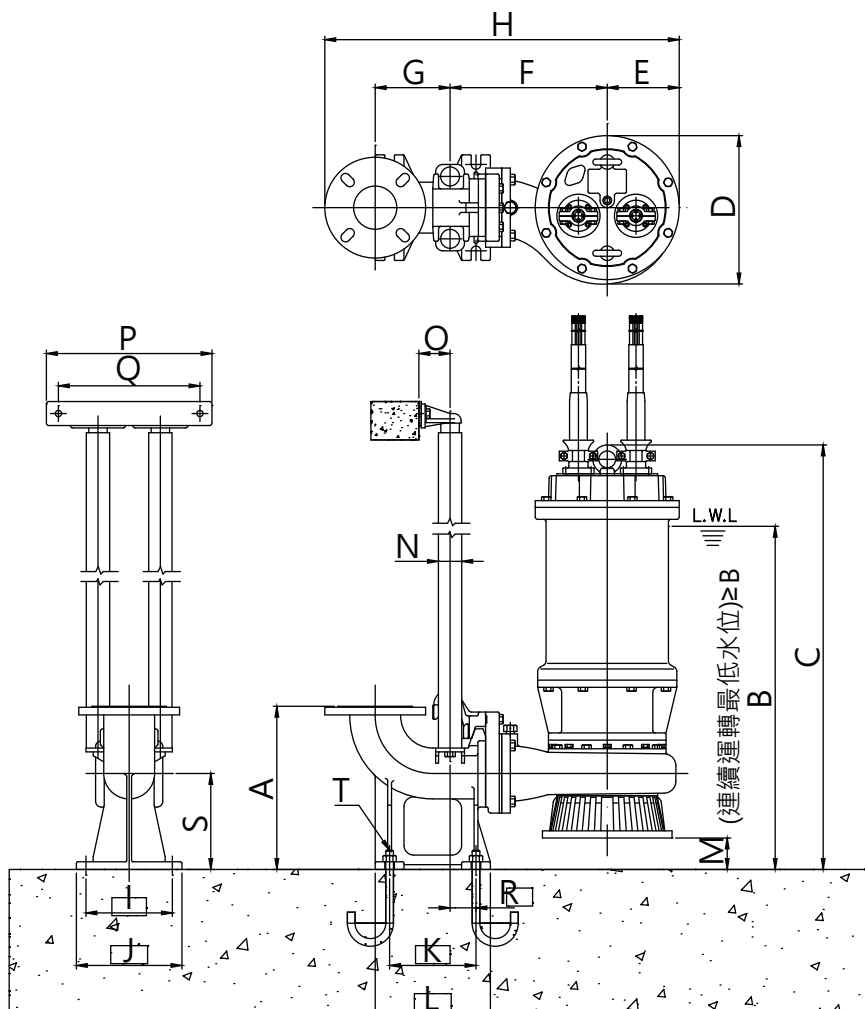





綠色 · 安全 · 永續經營

川源股份有限公司  
GSD INDUSTRIAL CO., LTD.



Changeable Market 以卓越的行動力  
should be satisfied with  
滿足市場快速變化 Superior Action

SPS-202105

Contact CMSA, scan now!



本型錄內容如有變更恕不另行通知 We reserve the right to contents without notice.